

Chiusura con prolunga a impronta triangolo 6

Codice prodotto: 160500

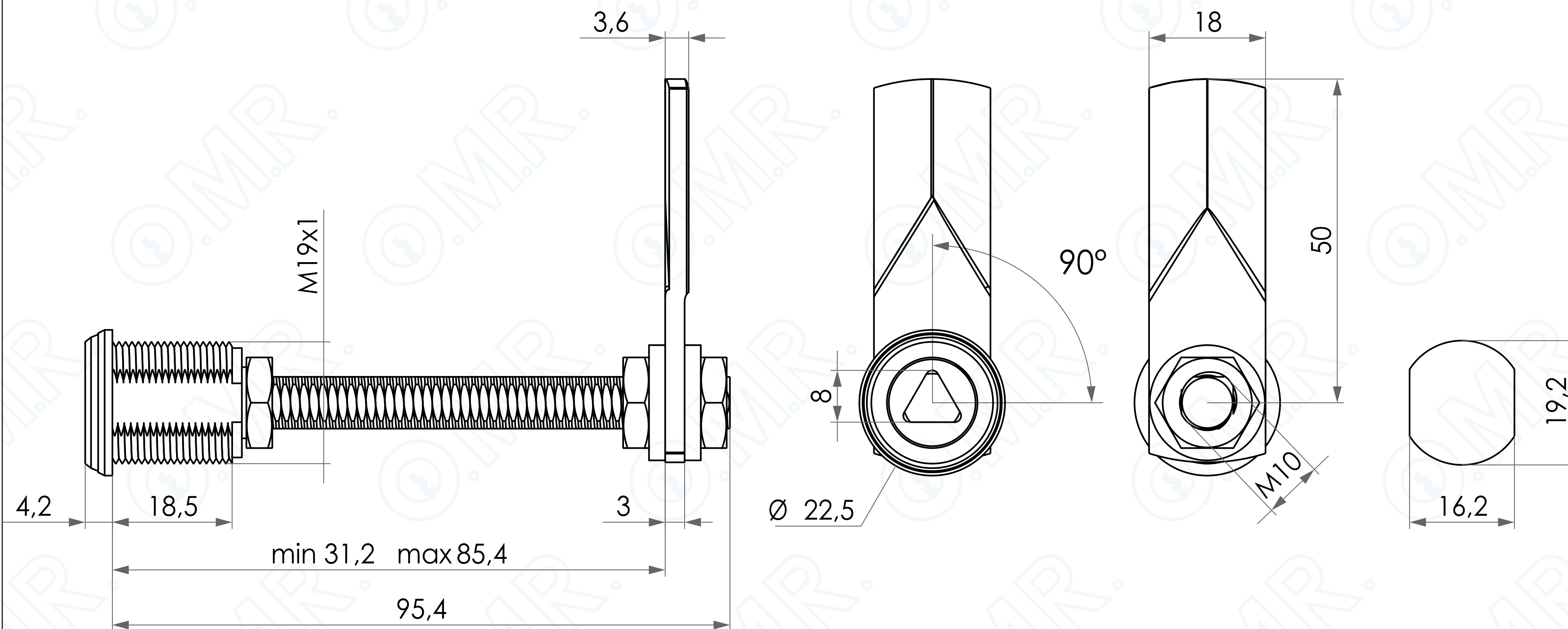

Cod. 160500



SCOPRILA ONLINE

